

FOXJET

# Labeling Series

*Spec.e*

## The Future of Automated Labeling

FoxJet's LS4700.e all-electric labelers help companies save energy and reduce costs.



Labeling Series  
*Spec.e*

### LS4700.e Features & Benefits:

- Wipe unit allows for up to 800 products per minute
- Tamp and corner wrap applications
- On-Board diagnostics
- Graphic touch-screen user interface
- Optional discrete I/O module or wireless/wired Ethernet module available
- Tamp unit offers quick change tamp pad
- RFID - ready

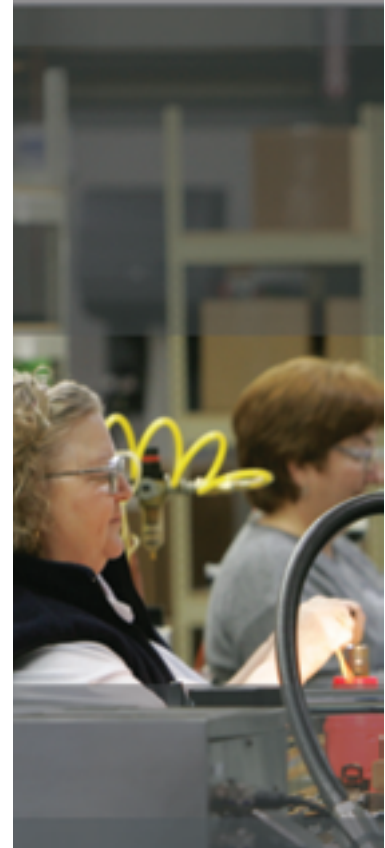

# Specifications



# Labeling Series *Spec.e*

## Specifications

<b>Maximum Labels/Minute</b>	<b>Wipe/WASA</b> Up to 800	<b>E-Tamp/E-FASA</b> Up to 150
<b>Dispense Speed</b>	15 to 300 fpm	15 to 200 fpm
<b>Minimum Media Dimensions</b>	0.5" W x 0.5" L	0.5" W x 0.5" L
<b>Maximum Media Dimensions</b>	6.0" W x 22" L	6.0" W x 13" L
<b>Supply Roll Capacity</b>	14" OD on 3" core	
<b>Power Supply Input</b>	110-240 VAC, 47-63 Hz, 2A Auto-Ranging	
<b>Optional Features</b>	Warning Tower, Label Present, Label Low, Ethernet	
<b>Environmental</b>	41-104° F (5-40°C); 15-85% RH Non-Condensing	
<b>Weight</b>	85 lbs. (38.5 kg) applicator and yoke, no stand	
<b>Certifications</b>	CE, TUV (UL 60950), complies with FCC, part 15 Class A	

## Dimensions

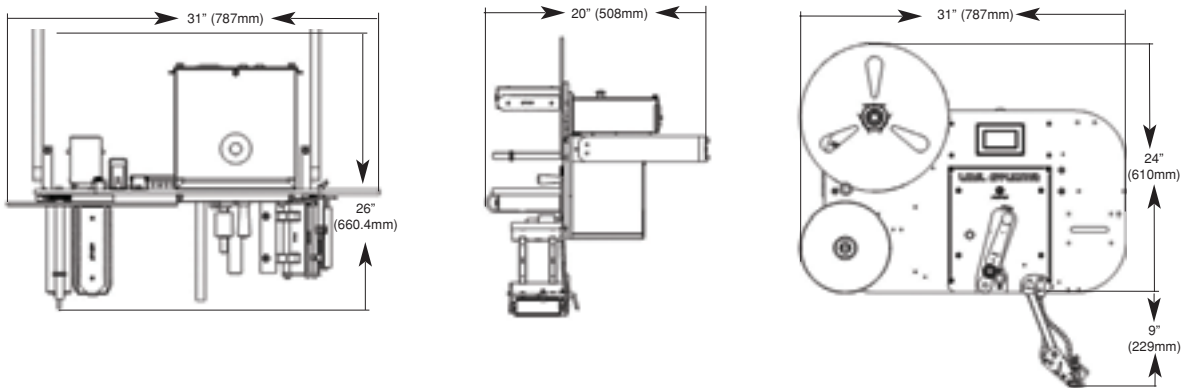

## Applications



## Distributor Information



Abbott Company  
 1413 Pearl Street  
 Waukesha, WI 53186  
 888.271.2112  
 262-522-3220 fax  
[www.abbottcompany.net](http://www.abbottcompany.net)



1 Missouri Research Park Drive • St. Charles, MO 63304  
 Ph: 800.369.5384 • Web: [www.foxjet.com](http://www.foxjet.com) • E: [email@foxjet.com](mailto:email@foxjet.com)

Labeling Series *Spec.e*

