

FOXJET

# Labeling Series

*Spec.e*

## The Future of Automated Labeling

FoxJet's LS4100.le is a compact automated labeler that offers high-end features for the value-minded customer. Designed for lower throughput applications, the LS4100.le utilizes high quality components for durability that maximize uptime.



## LS4100.le Features & Benefits:

- Wipe-On label applicator to meet most applications
- Patent-pending rewind drive system - no drive rollers
- Durable stainless steel peel blade
- Easy-to-read LED text display
- Accurate and reliable brushless servo motor
- Supports English, Spanish, Italian and Portuguese languages

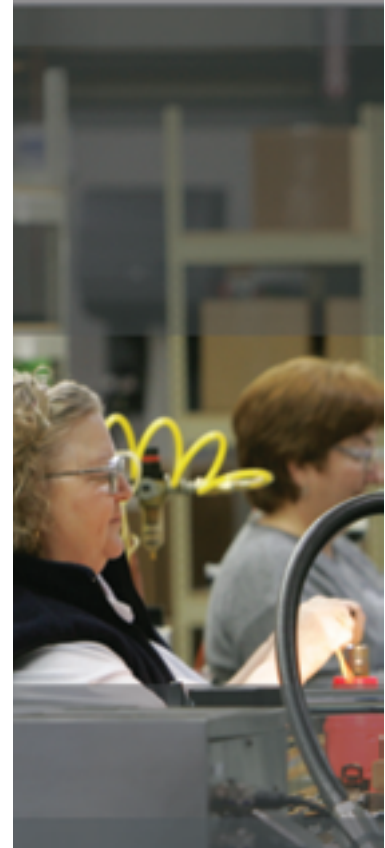

# Labeling Series *Spec.e*

Labeling Series *Spec.e*

## Specifications

<b>Maximum Line Speed</b>	80 fpm
<b>Minimum Line Speed</b>	10 fpm
<b>Minimum Media Dimensions</b>	0.75" W x 0.75" L
<b>Maximum Media Dimensions</b>	4.0" W x 8.0" L
<b>Supply Roll Capacity</b>	14" OD on 3" core
<b>Power Supply Input</b>	100-240 VAC, 50-60 Hz, 1.6A
<b>Environmental</b>	41-104° F (5-40°C); 10-85% RH Non-Condensing
<b>Weight</b>	38 lbs. (17.3 kg) applicator and yoke, no stand
<b>Certifications</b>	CE, CSA, FCC Approved, Listed (UL 60950)

## Dimensions

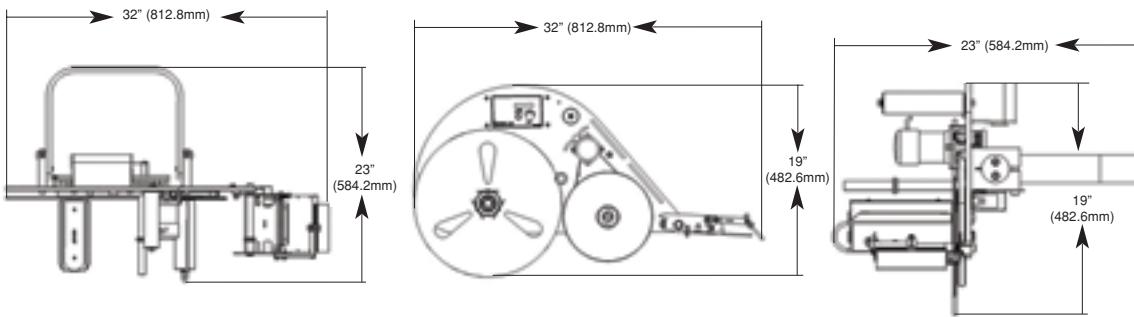

## Applications



## Distributor Information



Abbott Company  
1413 Pearl Street  
Waukesha, WI 53186  
888.271.2112  
262-522-3220 fax  
[www.abbottcompany.net](http://www.abbottcompany.net)

